

NOTES:

8 THREADS/INCH

8 BRIDGES

DEVIATIONS FROM REFERENCE DIMENSIONS WHICH DO NOT AFFECT FUNCTION ARE ACCEPTABLE.

HEIGHT DIMENSIONS SUBJECT TO VARIATION DUE TO "CRUSHING" DURING PART EJECTION.

ADD .010" FOR TOP EMBOSS.

THE DROP-LOK® CLOSURE IS NOT A VENTED CLOSURE AND SHOULD NOT BE USED ON APPLICATIONS THAT PRODUCE INTERNAL PRESSURE IN THE BOTTLE DUE TO CARBONATION, FERMENTATION, ETC.

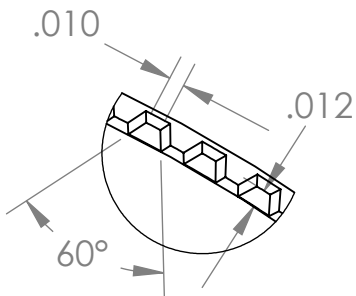

149 KNURLS

DETAIL B
SCALE 8 : 1

REVISIONS				
ZONE	REV.	DESCRIPTION	DATE	APPROVED
	A	CHANGED NAME IN TITLE BLOCK TO HOFFER	8/28/98	SJL
	B	REMOVED 1787 PLASTIC FINISH	3/1/99	SJL
	C	CHANGED THE 1.895 LINER DIAMETER TO 1.880	3/18/99	SJL
	D	REMOVED THE PULL-UP MARK	11/3/00	SJL
	D1	REDRAWN IN CAD	3/13/08	WEI
	E	REMOVED 1769 GLASS BOTTLE FINISH	5/19/08	WEI
	F	ADDED NON-VENTED CLOSURE NOTE.	3/16/12	WEI

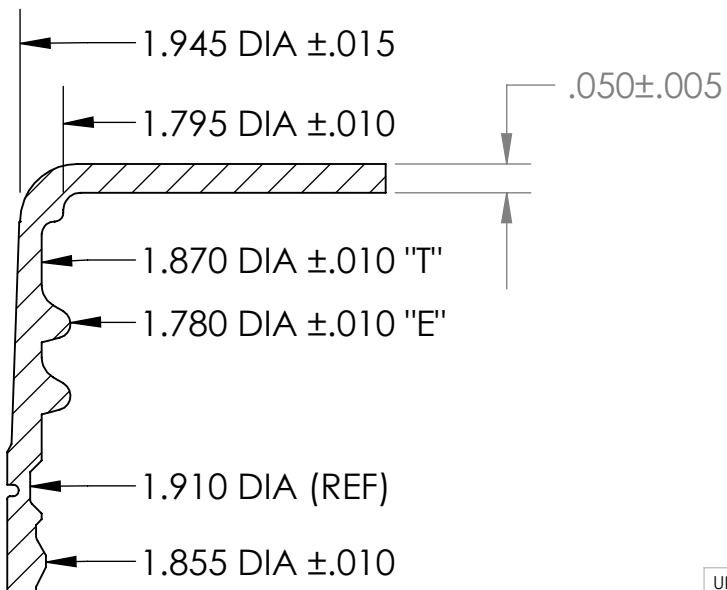
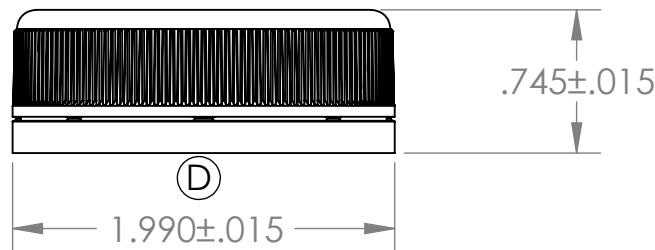
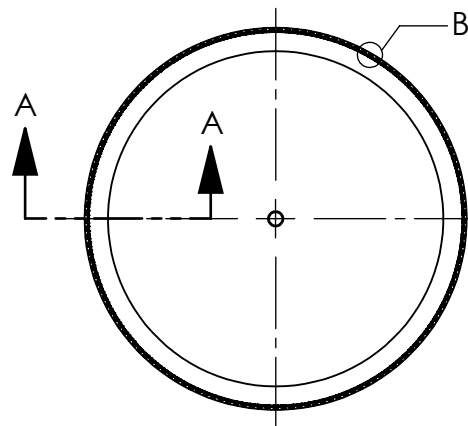

SECTION A-A
SCALE 3 : 1

GLASS FINISH: 1768 (E)

PLASTIC FINISH: 1763 (B)

PROPRIETARY AND CONFIDENTIAL

THE INFORMATION CONTAINED IN THIS DRAWING IS THE SOLE PROPERTY OF HOFFER PLASTICS CORP. ANY REPRODUCTION IN PART OR AS A WHOLE WITHOUT THE WRITTEN PERMISSION OF HOFFER PLASTICS CORP. IS PROHIBITED.

UNLESS OTHERWISE SPECIFIED:

DIMENSIONS ARE IN INCHES
TOLERANCES:
FRACTIONAL ±
ANGULAR: ± 1°
TWO PLACE DECIMAL ±.010
THREE PLACE DECIMAL ±.005

INTERPRET GEOMETRIC TOLERANCING PER:

MATERIAL POLYPROPYLENE

FINISH

DO NOT SCALE DRAWING

	NAME	DATE
DRAWN	WEI	3/13/08
DESIGN APPROVED		
COMMENTS:		
LINER:		
SS-222	1.880 DIA .030 ±.005 THICK	
EVA A-300	1.880 DIA .028 ±.003 THICK	(C)

Hoffer Plastics Corp.
500 N. Collins St.
So. Elgin, Il. 60177



TITLE:
**48 mm DROP-LOK®
(parabolic bridges)**

SIZE	DWG. NO.	REV
A	CA 48-24P	F

SCALE: 1:1 Shrink: SHEET 1 OF 1