

NOTES:

8 THREADS/INCH

DEVIATIONS FROM REFERENCE DIMENSIONS WHICH WILL NOT AFFECT FUNCTION ARE ACCEPTABLE.

HEIGHT DIMENSIONS SUBJECT TO VARIATION DUE TO "CRUSHING" DURING PART EJECTION.

ADD .010" FOR TOP EMBOSS.

THE DROP-LOK® CLOSURE IS NOT A VENTED CLOSURE AND SHOULD NOT BE USED ON APPLICATIONS THAT PRODUCE INTERNAL PRESSURE IN THE BOTTLE DUE TO CARBONATION, FERMENTATION, ETC.

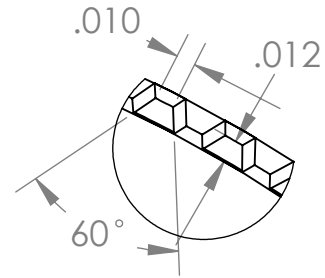

120 KNURLS
DETAIL B
SCALE 10 : 1

ZONE	REV.	DESCRIPTION	DATE	APPROVED
	A	CHANGED NAME IN TITLE BLOCK TO HOFFER	8/27/98	SJL
	A1	REDRAWN IN CAD	3/7/08	WEI
	B	REMOVED 1769 GLASS BOTTLE FINISH	5/19/08	WEI
	C	ADDED NON-VENTED CLOSURE NOTE	3/16/12	WEI

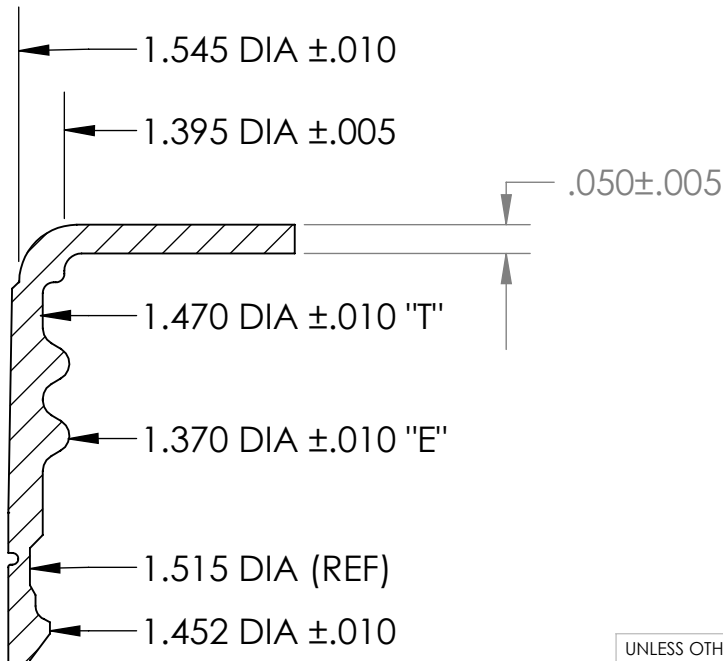

SECTION A-A
SCALE 3 : 1

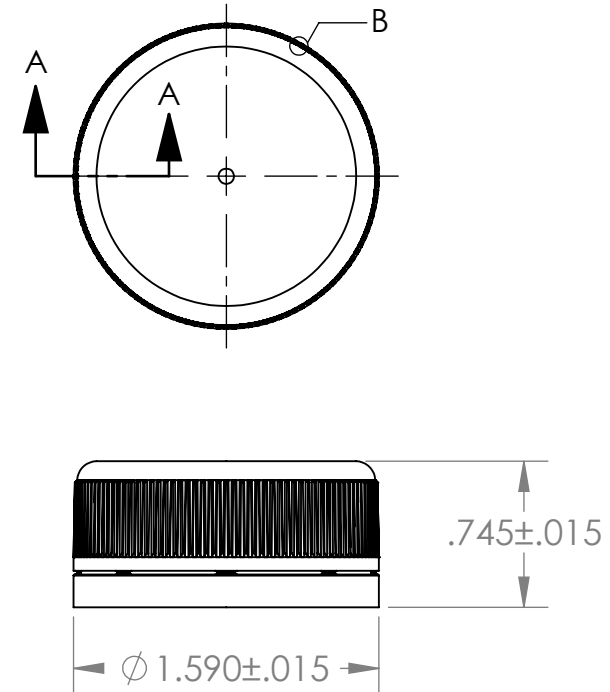

GLASS FINISH: 1768 (B)

PLASTIC FINISH: 1763 & 1787

PROPRIETARY AND CONFIDENTIAL
THE INFORMATION CONTAINED IN THIS DRAWING IS THE SOLE PROPERTY OF HOFFER PLASTICS CORP. ANY REPRODUCTION IN PART OR AS A WHOLE WITHOUT THE WRITTEN PERMISSION OF HOFFER PLASTICS CORP. IS PROHIBITED.

UNLESS OTHERWISE SPECIFIED:

DIMENSIONS ARE IN INCHES
TOLERANCES:
FRACTIONAL ±
ANGULAR: ± 1°
TWO PLACE DECIMAL ± .010
THREE PLACE DECIMAL ± .005

INTERPRET GEOMETRIC TOLERANCING PER:

MATERIAL
POLYPROPYLENE

FINISH

DO NOT SCALE DRAWING

	NAME	DATE
DRAWN	WEI	3/7/08
DESIGN APPROVED		
COMMENTS:		
LINER:		
SS222	1.480 DIA .030 ±.005 THICK	
EVA A-300	1.480 DIA .028 ±.003 THICK	

Hoffer Plastics Corp.
500 N. Collins St.
So. Elgin, IL 60177



TITLE:

38 mm DROP-LOK®

SIZE	DWG. NO.	REV
A	CA 38-18	C

SCALE: 1:1 Shrink: SHEET 1 OF 1